

The Sage Advisor



SCADA, SECURITY & AUTOMATION NEWSLETTER

Volume 26, Issue 2 • Fall 2016

A Publication of Sage Designs, Inc.

What IT Doesn't Get About SCADA

Reconciling Conventional IT Staff with Emerging SCADA

Today's SCADA professional holds a wide range of responsibilities and may be employed in one of several industries, but almost always enjoys the same nemesis: IT staff.

As the cost and labor savings of SCADA systems have become more significant, SCADA systems have grown and expanded to overlap the networking responsibilities traditionally held only by Information Technology professionals. This overlap can cause so much tension that nearly everyone in the SCADA industry has a story or two about negotiating with IT.

SCADA technology is here to stay, however, and there is a middle ground between IT practices and SCADA necessities, in a role that we advocate bringing into every major SCADA system: The Industrial Network Specialist. To create an Industrial Network Specialist (INS) requires similar training to IT or advanced SCADA networking, with a difference in principles and focus. An INS will have a deep understanding of real-time communication needs as they relate to the operation of an industrial process. They understand that a loss of communication can mean the loss of control of a process, resulting in *real and physical*

consequences to staff, the public, business, and infrastructure. An INS will be trained, equipped, aware of, and dedicated to their role.

The INS must never have a conflict of interest in the operational process. Changes and security must be implemented under a single movement coordinated tightly with the running environment, supporting SCADA members, networking security, and operations. The INS knows this can only be done properly under a common management umbrella.

The INS approach to a problem should be rooted in Availability, Integrity, and Confidentiality. The specialist understands that for automation systems to function the first and foremost need is for correct and available data. *This is the opposite of a standard IT network.* The specialist must operate with a protect-the-process approach rather than a protect-the-confidentiality of the data approach.

An IT professional values minimal disruption to a daily work environment, and seeks to perform work outside of traditional working

[What IT Doesn't Get Continued on Page 7](#)

Free Hands-On Radio Seminars Coming in November



radio with two Ethernet ports and two serial ports and a protocol converter to seamlessly bridge between Modbus TCP and Modbus RTU protocol devices. The MR-450

Sage Designs is pleased to announce the return of our popular series of technical seminars. This year we will host a one-day technical presentation and hands-on training session on several important technical subjects.



Joel Weder, Senior Applications Engineer for Trio radios in North America, will be presenting the technical session. His half-day presentation will concentrate on radio theory with topics such as Fade Margins, Path Losses, Antenna Selection and other topics. This session is recommended for anyone who is working with radios and wishes to better understand the theory behind radio signal propagation and why radios work (or don't) the way they do. Joel will also discuss some of the advanced networking capabilities of the JR and QR radios and the innovative approach Trio has taken in building these advanced radio products.

The second half of the day we will break out into stations where participants will be able to watch and participate first hand with the configuration three models from Schneider Electric's Trio radio line concentrating on the JR-900, the MR-450 and the new QR-450 radios. The JR-900 is the unlicensed Spread Spectrum radio from Trio and boasts two Ethernet ports, two serial ports and two antenna ports. The QR-450 is the UHF licensed radio which boasts 32 Kbps over the air transmission and is a native Ethernet

is the low-cost serial licensed UHF radio which can be used in conjunction with the QR-450. We will demonstrate the configuration of radios for many of the tasks they may be called on to perform in a simple or complex radio network. This session is recommended for anyone currently using these Trio products or contemplating their use in an upcoming project, or someone wishing to know more about the Trio line of radios in general.

Participants may reserve a seat for one or both sessions, depending on their interest. A continental breakfast will be provided for all attendees to the morning session. For those attending both sessions, lunch will be provided. Please see the registration form on our website for additional details and to reserve your seat!



Interested attendees can stay informed about this event by signing up for our mailing list or contacting your local Sage Designs representative! Please see our expanded seminar information on Page 7 for additional details.

Inside this issue:

- Training & Events
- A More Convenient Rollover Counter
- Pillbox Updates & Improvements
- What Datasheets Don't Say

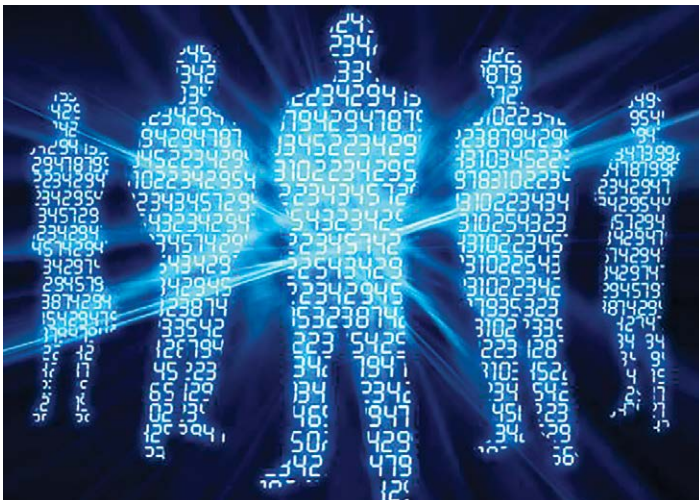

Retained Counter With Rollover at 10,000

The other day a customer, who was replacing their outdated equipment with a new SCADAPack, asked me how to make a totalizer that would roll over at 10000 rather than 65535. Apparently the device being replaced was designed with 10000 in mind and the customer stood to save a considerable amount of effort on the SCADA server side by presenting their data in a matching format. As many of our customers may one day find themselves in a similar situation, here we present our solution.

Since the incoming pulse rate was fairly slow (in the several seconds between pulses range) the solution is simple two-step process:

Step One:

Look at one of the built-in counters on the SCADAPack mother board

and compare it each time to a register labeled Pulse Detect.

Step Two:

If the counter input has incremented, trigger an output and update the Pulse Detect so that it matches the first 16-bit word of the 32-bit counter input register and then count these triggers in an up-counter in the Count to Limit 42000 register.

In addition to providing the 10000 trip point in the counter, this also highlights one way to deal with the issue that a 3xxxx register is not retained if power is lost. In this example (which could also count to 65535) the 4xxxx register also holds the count without power for up to several years making this function handy in other circumstances.

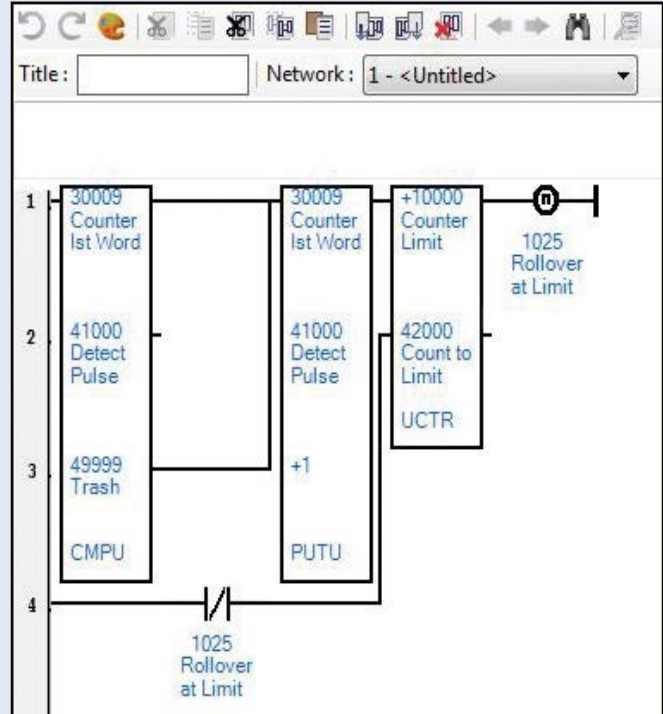

Pillbox Panel Now Accommodates Larger Controllers

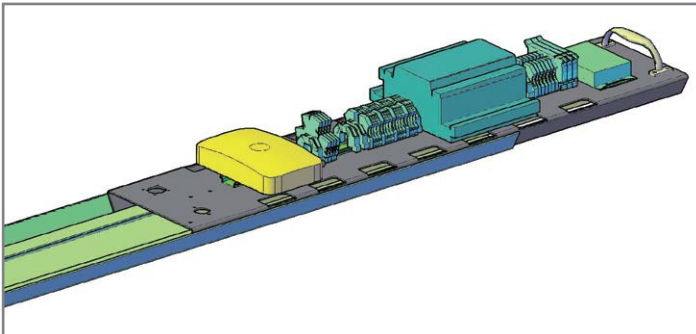

Acknowledging the need for more flexibility in a customer's choice of what they want to use inside a Pillbox, we have redesigned the Pillbox panel to allow it to accommodate any model of SCADAPack currently in production, plus other larger controllers and equipment. We effected the change with no increase in the enclosure's outer dimensions by inverting the shape of the panel to make it less restrictive on the "height" (the amount of space above and below the DIN rail assuming a horizontal mounting orientation) of modules mounted on the DIN rail. Now instead of about 1 1/2" above and below, we have closer to 2 1/2" allowing room for the double-stacked SCADAPacks, the largest of which is just over 6" total height. This redesign has no negative impacts on the allowable "depth" of modules, about 4".

This update allows for the mounting

of other products, such as larger case SCADA radios like the older Trio E series or the bulky radios of many Trio competitors or other controllers or electronics, without the use of special brackets that elevate the cases above the DIN rail like previous PillBox models. This update will also allow an option to increase the battery capacity of a PillBox by ordering a longer body which will add space for an additional 35 AH battery increasing the overall capacity to about 100AH supply.

The PillBox enclosure is a flexible, secure housing, ideal for many applications. Let us know your special needs and we will modify the PillBox to suit.



SCADAwise™ Training Classes

ClearSCADA

SCADAPack

ClearSCADA Level 1 Training Course

March 20-23, 2017 — Mill Valley, CA
May 15-18, 2017 — Ontario, CA

- Day 1 (8AM - 4PM) Installing ClearSCADA, Introduction to ClearSCADA, Components, Using ViewX, Using WebX, ClearSCADA Help
- Day 2 (8AM - 4PM) Configuring using ViewX, Database Organization, Basic Telemetry Configuration, Creating Mimics, Creating Trends
- Day 3 (8AM - 4PM) Configuring using ViewX, Templates & Instances, Logic Languages, Security, Communications Diagnostics
- Day 4 (8AM - 4PM) Reports, System Configuration, System Architecture, Questions

Cost: ClearSCADA Training Course \$2,200

Sage Designs' ClearSCADA Level 1 Course has been certified by (a) the California Department of Public Health as courses qualifying for contact hour credit for Water Operator Certification for Drinking Water Treatment or Distribution in the State of California and (b) the State of Nevada Department of Environmental Protection, Bureau of Drinking Water for contact hours towards the Nevada Drinking Water Operator Certification Program.

(28 Contact Hours)

Telepace Studio Training Course

March 14-16, 2017 — Mill Valley, CA
May 2-4, 2017 — Ontario, CA

- Day 1 (8AM - 4PM) SCADAPack controller operation, Series 5000 I/O, Telepace Studio introduction
- Day 2 (8AM - 4PM) Telepace Studio advanced programming techniques and advanced functions
- Day 3 (8AM - 2PM) Controller communications, Modbus Master/Slave protocol, Diagnostics, Modems

Cost: SCADAPack Telepace Studio Course \$1,650*

* You must have a licensed copy of Telepace Studio installed on your computer for this course. If you do not have a licensed copy, you may purchase one with the class at a special course price. Course price for Telepace Studio: \$510 + applicable CA sales taxes

Sage Designs' Telepace Studio Course has been certified by (a) the California Department of Public Health as courses qualifying for contact hour credit for Water Operator Certification for Drinking Water Treatment or Distribution in the State of California and (b) the State of Nevada Department of Environmental Protection, Bureau of Drinking Water for contact hours towards the Nevada Drinking Water Operator Certification Program.

(20 Contact Hours)

ClearSCADA Level 2 Training Course

2017 Dates TBD

- Day 1 (8AM - 4PM) Installation, Understanding the Architecture of ClearSCADA, Application Design Considerations, Server Automation Interface, ClearSCADA Logic Engine, Using ODBC and SQL.
- Day 2 (8AM - 4PM) Advanced Mimic Design and Techniques, Data Grids and Data Tables.
- Day 3 (8AM - 1PM) Accessing Historical Data, Ad Hoc trends, Archiving

Prerequisite: ClearSCADA Level 1 Training Course

Cost: ClearSCADA Level 2 Training Course \$1,650

(20 Contact Hours)

Instructors: ClearSCADA Level 1 & Telepace classes will be taught by Tony Sannella, Sage Designs, a Factory-Certified Instructor. SCADA Level 2 classes will be taught by a SEUSA-certified training instructor. The ClearSCADA Test Drives will be conducted by Sage Designs or a factory representative.

Location: See individual course registration form. Those requiring overnight accommodations should call the hotel directly for reservations.

What should I bring? Laptop computer with minimum requirements as shown on the specific course registration forms, plus necessary permissions to install software on your computer.

*You must have a licensed copy of Telepace Studio to take the Telepace course. We offer a course price for a license or you may purchase through your local Schneider Electric TRSS representative.

What is provided? Course manual, daily continental breakfast, lunch & beverages.



Schedule Your Own ClearSCADA Test Drive

Free Hands-On Test Drive

Call to Schedule a Test Drive
Call 1-888-ASK-SAGE
email: info@scadawise.com

SAGE DESIGNS, INC.
SCADA & Security Products



Download the Registration form at: <http://www.SCADAwise.com>

*** * * Registration Deadline: 4 weeks before 1st day of course * * ***

All registrations are subject to cancellation fees. A confirmation notice will be sent to all registrants on or before the deadline date.

Datasheet Specifications Don't Tell the Whole Story

You can have long range or high data-throughput rates, but not both at the same time.

- **Speed:** Actual data speeds for different wireless Ethernet radios are more functionally comparable than one might expect after taking a quick look at product datasheets. A few key factors determine the throughput of a spread spectrum radio, whether it's being tested in a lab or operating in a real-world environment. Some manufacturers claim their radios achieve data speeds of 512kbps to 1Mbps – but often times, radios set to higher speeds will actually communicate much slower. Still others claim unusually high rates of 5–12Mbps. But are they talking about over-the-air, or actual data throughput?
- **Distance:** Some datasheets describe radios covering very long distances (typically qualified by statements saying actual results depend on things like antenna height and terrain). However, in wireless networks, distance and speed work against each other. To operate at optimum performance levels, a radio is very unlikely to achieve these stated specifications.

Optimizing Your System: Trade-Offs Between Speed, Distance, & Performance

Providing substantial channel bandwidth is an essential step when designing a robust wireless infrastructure. But it's important to understand the big picture: An incorrectly designed system can produce a bottlenecked network that performs at what seems like sluggish speeds with poor reliability.

Several things are major contributing factors that determine what you will get from an actual SCADA application, versus what the specifications say on paper.

Key Factors Influencing Wireless Ethernet Network Performance

- Actual data throughput (including packet retries/repeats)
- Channel bandwidth
- Message length
- Distance/operating range
- Interference & obstructions

Example:

Determining actual throughput for a 512kbps radio

Several manufacturers claim their radios cover an extended range at over-the-air throughput of 512Kbps (they qualify that by saying actual performance is influenced by antenna height, obstructions, terrain, etc.).

- To achieve this high throughput, the specifications typically say the radio Bit-Error-Rate (BER @ 1×10^{-6}) is at -92dBm. Real-world experience has shown that an RSSI of at least -77dBm would be required, with an SNR of +26dBm or better. However, even if this was achieved, actual throughput would be 300-380kbps at best. The rest of the so-called 512kbps would be consumed by overhead and retry packets.
- Although it is possible to get RSSI around -70dB, it's difficult to keep SNR in the +26dBm range. Other 900MHz spread spectrum systems may be nearby, and other in-band and out-of-band noise may be present.

The above example is for a fixed application, such as a SCADA network. In a mobile Ethernet environment, reliably getting SNR at the desired +26dBm is nearly impossible. For instance, in most cases, the radio would be set to 256kbps using 2 level modulation: This would correspond to a Bit-Error-Rate (BER @ 1×10^{-6}) of -99dBm, which translates to an RSSI of a remote to a master radio no worse than 5dBm. The resulting SNR of +21dBm would net a throughput around 180kbps.

Best practice: Send shorter messages

The reality is that as soon as data is transferred through the air, successful communication becomes a game of probability – and you want to make sure the odds are in your favor. Best practice is to send more short messages, rather than fewer long ones, to mitigate potential bottlenecking and other negative effects. Smaller data segment packets, coupled with fast hopping times, greatly improve the chances of successful data transfer.

Distance comes at a price

Optimizing a wireless Ethernet radio network doesn't equate to achieving the longest distances possible.

Some manufacturers claim operating distances of 20, 40, or even 60 miles. This may be technically correct, but there's a trade-off: Longer operating range (distance between two radios) happens at slower data speeds, while faster speeds are achieved over shorter distances.

Bandwidth also comes at a price: Wider channel bandwidth allows more data transfer

However, keep in mind that wide band can defeat the purpose by allowing more noise, causing system performance to drastically decrease. To counter this situation, a stronger

receive signal strength indication (RSSI) and higher signal-to-noise ratio (SNR) will be required, which in most cases means that the radios need to be in closer proximity – reducing the overall operating range of the system.

Real-World Examples

Below are some real-world examples illustrating key points from this discussion. These are not intended to falsify any manufacturer's performance claims. Rather, the idea is to demonstrate the trade-offs between distance, bandwidth, and speed in actual wireless Ethernet networks, and to show how product datasheets don't tell the whole story.

Example: A 512kbps radio can give you 256kbps (or less)

In either a fixed or mobile wireless Ethernet network, if you hard-set a radio to the 512kbps mode, but the RSSI and SNR are not at desired levels, your actual data-throughput speed will be lower than if the radio had been set to 256kbps. Why? Because of TCP data segment retries, which rapidly diminish actual throughput.

- Frequently, an auto-baud rate setting can be selected instead – but again, if the RSSI and SNR are not at adequate levels, the radio will switch back to 256kbps anyway. In this situation, the radio will de-associate and then re-associate, again slowing

your data-throughput speeds.

- Some radios in the field today use a channel bandwidth of 316.5kHz, which is why the 256kbps works well: In conventional 2-level modulation, the data throughput speed is not greater than the allotted bandwidth, so the 316.5kHz allows the radio to perform better (because the 256kbps throughput is lower than the allotted bandwidth).

To achieve 512kbps, you would need 4-level modulation, which requires a stronger and more reliable signal.

Example: Radios specified at 512kbps–1Mbps with 600kHz bandwidth

Recently, some manufacturers have claimed over-the-air data rates of 512kbps and 1Mbps at 600kHz.

This wider bandwidth allows for 2-level modulation that nets an over-the-air data rate of 512kbps, with a resulting actual throughput of 300-380kbps.

Although greater data speeds are possible, this places limits on distance, while increasing the chance of interference because of the larger bandwidth. In addition, more bandwidth means the radio makes fewer hops, decreasing its flexibility. Because operating distances are lower, more investment in infrastructure (master radios) is required to achieve the higher

Datasheet Specifications Continued on Page 6

Life Is On



Water network security here.

For the ultimate water fight here.



Whatever the size and complexity, ensuring safe, reliable and secure operation from field to enterprise

Flexible I/O configuration to handle expansions
Reduce engineering time with replicated object templates

SCADA Components:

- SCADA Expert ClearSCADA management software
- SCADAPack Smart RTUs & rPACs
- Accutech wireless instrumentation
- Trio data radios



For more information, live equipment demonstrations, a listing of contact-hour certified classes near you, or to schedule a consultation on solving your SCADA challenges, contact your local Schneider Electric | TRSS representative:



(888) 275-7243
www.sagedesignsinc.com
www.scadawise.com



© 2016 Schneider Electric. All rights reserved. Schneider Electric, Life is On, Accutech, ClearSCADA, SCADAPack and Trio are trademarks and the property of Schneider Electric SE, its subsidiaries and affiliated companies. All other trademarks are the property of their respective owners.

throughput speeds. Therefore in most cases, these radios are set to the 512kbps, especially in mobility situations.

Example: Trio J-Series Ethernet radio

Schneider Electric offers a Trio J-Series Ethernet radio which uses a 360kHz bandwidth and passes 256kbps of data using 2-level modulation. As discussed above, a product with these specifications compares favorably to many radios claiming higher over-the-air data throughputs. (It can also be configured to a 512kbps over-the-air data rate with 4-level modulation.) But in many cases, this radio will face the same issue that others encounter: The speed can't be higher than the allotted bandwidth. Unless a network can achieve the recommended RSSI and SNR levels, a radio set to higher speeds will often end up communicating at 256kbps – and in some cases even less, because of TCP packet retries.

Key Factors Influencing Wireless Ethernet Radio Network Performance

Channel Bandwidth – The difference between the lowest and highest frequency in which a channel resides during each hop in a frequency-hopping spread spectrum (FHSS) radio system. The wider the bandwidth, the more data can be passed during each frequency hop. Typically, actual data speed is never greater than the channel bandwidth allotted (assuming 2-level modulation). In spread spectrum, you are not restricted to a minimum bandwidth; FHSS allows 100kHz, 200kHz, even 680kHz. However, although more bandwidth allows more data to be pushed through in a given period of time, remember that doing so sacrifices operating distance. And as bandwidth increases, this opens the radio receiver up to allow more noise and/or interference. This is a main factor in decreasing operating distance, and it is where signal-to-noise ratio (SNR) comes into play.

Modulation – RF industry standard has traditionally been 2-level modulation, which gives radios good sensitivity at the receiver, but poor multipath distortion performance. Some radios now accommodate 4-level modulation, allowing up to twice the data throughput speeds; however, this sacrifices sensitivity, which reduces operating distance.

Example of higher-order modulation specifications				
	3.5 MHz bandwidth mode		1.75 MHz bandwidth mode	
Modulation scheme	Sensitivity	Raw bit rate	Sensitivity	Raw bit rate
64 QAM	-77 dBm	12.7 Mbps	-80 dBm	6.35 Mbps
16 QAM	-86 dBm	4.8 Mbps	-89.5 dBm	2.4 Mbps
QPSK	-92 dBm	2.4 Mbps	-95 dBm	1.2 Mbps
BPSK	-92 dBm	1.2 Mbps	-98 dBm	600 Kbps

Other types of higher-order modulation, such as GFSK, BPSK QPSK, QAM 16, or QAM 64, allow faster speeds. But as with 4-level, reliably receiving data at higher rates requires much stronger RSSI and SNR. Otherwise, each data packet will need to be sent multiple times, drastically reducing throughput rates. In some cases, actual speeds are slower than if 2-level modulation were being used.

Receive Signal Strength Indication (RSSI) – This is the measurement in decibels per milliwatt (dBm) of the received radio signal strength (not the quality of the signal). This indicates the strength of each remote radio relative to the master radio in a SCADA network. Manufacturers state a recommended minimum RSSI level to achieve reliable radio performance. In terms of actual measurement, this is stated in terms of -xxdBm, where xx is a numeric RSSI reading.

Signal-to-Noise Ratio (SNR) – The ratio of a radio's signal to noise that is corrupting it; for example, SCADA data compared to background noise. In RF, this is defined in terms of +dBm. Example: To reliably receive a signal using 4-level modulation, SNR usually needs to be at least +25dBm. So if a receiver is hearing noise at a level of -95dBm, then the RSSI of the remote radio must be -70dBm (-95 + 25 = -70). If SNR dropped below +25dBm, then it may be better to switch to 2-level modulation, which works adequately in an SNR range of +18dBm. Considering the same example, to meet the minimum SNR requirement at 2-level modulation, RSSI should be -77dBm (-95 + 18 = -77dBm): The system has gained +7dBm of signal quality.

Distance – The greater the distance between a master and remote radio, the less likely data will arrive intact. A minimum RSSI and SNR must be maintained between them to ensure reliability and performance. For a 3-mile link with the data rate set to

512kbps, one would expect an actual throughput around 380kbps, which is quite reasonable. But if the same settings were used over 25 miles, the required RSSI and SNR thresholds would probably not be met. The radios may remain linked, and the settings may indicate a data speed of 512kbps, but in reality each packet of data would probably be sent multiple times, reducing actual throughput to only 80–200kbps.

Data Segment Packet – Smaller data segment packets, coupled with fast hopping times, greatly improves the chances of successful data transfer.

Dwell Time – The length of time a radio stays on a given frequency before hopping to the next one in its sequence. Ideally, a radio should be flexible enough to change from short (10ms) to long (200ms) dwell times, allowing operators to fine-tune system performance. A shorter dwell time lowers the chance a radio will incur interference. Longer dwell times can typically be used only for point-to-point systems; in many point-to-multipoint SCADA systems, these longer times will severely cripple system performance.

Radio Sensitivity – The manufacturer's specified radio sensitivity in terms of Bit-Error-Rate (BER = 1x10⁻⁶ @ -99dBm). This means that in a perfect lab environment the radio will receive (1)-bit error for every (1,000,000) bits passed at an RSSI level of -99dBm. In the real world, if you were to design a radio network to these ideal specifications, that radio would not operate correctly: The rule of thumb is to design a system so the RSSI of the remote back to the master is at least 20dBm higher than the stated BER (for stated BER between -100dBm and 110dBm). For stated BER between -90dBm and -99dBm, design the actual remote RSSI at least 15dBm higher. This is also commonly referred to as fade margin.

Fade Margin – The measure in dBm between a manufacturer's stated radio

sensitivity in terms of BER, and the real-world minimum recommended RSSI of the remote as it relates back to the master. Example: For a radio with stated BER = 1x10⁻⁶ @ -99dBm, the fade margin would typically be +15dB. Because -99 + 15 = -84dBm, -84dBm would be the minimum recommended RSSI for the remote radio.

Interference – Radio interference comes from other sources using the same frequency band: The greater the amount of interference the less likely data will arrive intact. This is where the quality and performance of the radio comes into play. Most industrial radios design RF filtering into the front-end of the radio receiver to help suppress unwanted signals. This is sometimes not enough, and external reject/notch filters are required.

TCP Packet Retries – As the probability of successful communication decreases, the number of retries increases, resulting in more traffic and data collisions, lower throughput speeds, and possibly failed communications. In a TCP/IP over RF system, flow control, error correction, and congestion control are handled by the TCP/IP layers. But noisy media result in extra traffic due to TCP retries caused by unacknowledged data segments packets.

Physical Obstruction – The more obstructions along the radio path, the less likely it is that data will arrive intact. Again, this is why RSSI and SNR are so important in radio system design. The 900MHz ISM (industrial, scientific, and medical) band is more forgiving to certain obstructions than are the 2.4GHz and 5.8GHz ISM bands.



hours. This is the opposite of the INS procedure. The INS understands that without automation a process requires human labor. The specialist approaches maintenance periods or downtime from the perspective that work should be done during business hours when the maximum amount of people can be made available to manually operate any process. The specialist will work closely with the operations team in the knowledge that the greatest safety for both staff and the public comes from performing work when the most people are on hand to deal with emerging problems.

The INS will have to get their hands dirty in unconventional environments. Industrial environments are loud and busy places, sometimes in remote locations. The Industrial Network Specialist will be at home in a 4-wheel drive. They will be familiar with best practices in the automation and controls industry and aggressively seek ways to follow those practices to maintain the availability and integrity of the industrial network.

A conventional IT professional knows a range of technologies and interfaces. An Industrial Network Specialist will add to those traditional IT technologies the ability to script and automate tasks on the SCADA network,

both to increase productivity of the SCADA team and ensure consistent results. They are aware of NIST and ISC-CERT best practices and aggressively seeks ways to follow those best practices to maintain the availability and integrity of the industrial network. They may also require training on other certifications and security standards such as NERC, FERC, CSSA, ICS-CERT and others.

Standard IT equipment hold a 1-to-5-year life cycle to stay ahead of technology. The Industrial Network Specialist understands that the component lifetime for an industrial network differs from the usual timetable with a life expectancy of 10-15 years or more. Specifically, equipment system lifecycles, industrial (real-time) protocols, QOS management, real-time (control) system (as compared to transactional; invoice system) consequences.

What we've defined here are some practical examples of the differences between IT and SCADA network management, of which there are many, but they can be summarized in the most important distinction: As their core operating principle, the INS should be aware that the industrial network must operate *continuously and uninterruptedly* in order for the companies' core business to succeed.

Free Hands-On Radio Seminar

November 1st, 2016 — Stockton, CA

November 3rd, 2016 — Redding, CA

Early Session (8AM - NOON)

Radio Theory incl. Fade Margins, Path Losses, Antenna Selection

Late Session (1PM - 5PM)

Hands-On Demonstration of Trio series incl. J-series 900mhz, M-series licensed UHF, and Q-series native Ethernet licensed radios

Cost: FREE (with required registration)

Pill SCADAwise BOX

The Pillbox™ is a self-contained housing for field installation of electronics packages that need protection from the elements as well as unwelcomed attention. Inside, there is up to 3 sq. ft. of panel space with 3' of mounting DIN rail for mounting equipment and 3' of wiring Panduit. The equipment panel slides in behind the retainer system which allows for easy removal of all mounted components. The bottom of the retainer system includes a battery tray allowing the removal and service of the batteries without tools for disassembly.

- ✓ Easy to Install
- ✓ Low Maintenance
- ✓ Tamper-resistant
- ✓ Engineered Solution

For more information contact:

SAGE DESIGNS, INC.
SCADA & Security Products

150 Shoreline Hwy., #8A, Mill Valley CA 94941-3634
1.888.ASK.SAGE / www.sagedesignsinc.com

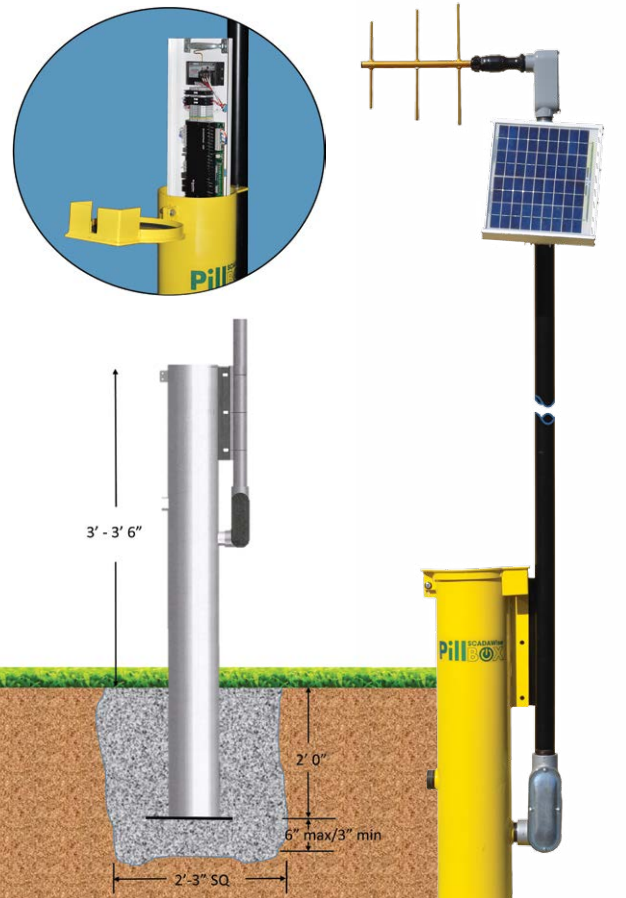

150 Shoreline Hwy., Suite #8A
 Mill Valley, CA 94941-3634

Return Service Requested

🌲 SAVE A TREE

The Sage Advisor

SCADA, SECURITY & AUTOMATION NEWSLETTER

Calendar of Events

- October 25-26, 2016 **CA-NV AWWA Fall Conference**, San Diego, CA
- January 18, 2017 **USBR Mid-Pacific Region Water Users Conference**, Reno, NV
- January 30-31, 2017 **CA Irrigation Institute Annual Conference**, Sacramento, CA
- March 14-16, 2017 **Telepace Studio Ladder Logic Training Course***, Mill Valley, CA 
- March 20-23, 2017 **ClearSCADA Level 1 Training Course***, Mill Valley, CA 
- April 10-13, 2017 **CA-NV American Water Works Assoc. Conference**, Anaheim CA
- April 25-28, 2017 **CWEA Annual Conference**, Palm Springs CA
- May 2-4, 2017 **Telepace Studio Ladder Logic Training Course***, Ontario, CA 
- May 15-18, 2017 **ClearSCADA Level 1 Training Course***, Ontario, CA 
- August, 2017 **Wine Country Water Works**, Rohnert Park CA
- September, 2017 **Monterey Bay Water Works**, Monterey CA

*Download the registration form from our website or call for more information.

SAGE DESIGNS, INC.
SCADA & Security Products











SCADA

ClearSCADA Enterprise Software
 SCADAPack RTU/PLC Controllers
 FlowStation Pump Controllers
 Pillbox Ruggedized SCADA Enclosures
 WIN-911 Alarm Notification Software
 ScadaDroid Alarm Dialer

WIRELESS

Accutech Wireless Instrumentation
 Trio Spread Spectrum & Licensed Radios
 Teledesign Systems VHF & UHF Licensed
 FreeWave Spread Spectrum Serial & Ethernet

SECURITY

Video Surveillance, Hardware & Software

MS4 PERMITTING SOFTWARE

1-888-ASK-SAGE
SageDesignsInc.com • SCADAwise.com